

OPERATING, INSTALLATION AND SERVICE MANUAL FOR INSTALLATION IN RECREATIONAL VEHICLES AND MOBILE HOUSING

HOT WATER STORAGE HEATER MODELS SW5EA • SW7EA



MANUFACTURED BY AIRXCEL, INC. - SUBURBAN DIVISION

FREEZE WARNING

DRAIN HEATER IF SUBJECTED TO FREEZING TEMPERATURES

WARNING: IMPROPER INSTALLATION, ADJUSTMENT, ALTERATION, SERVICE OR MAINTENANCE CAN CAUSE INJURY OR PROPERTY DAMAGE. REFER TO THIS MANUAL FOR ASSISTANCE OR FOR ADDITIONAL INFORMATION CONSULT AN AUTHORIZED INSTALLER OR SERVICE AGENCY.

ADDITIONAL SAFETY

DO NOT STORE OR USE PETROL, OR OTHER COMBUSTIBLE MATERIALS OR LIQUIDS NEAR OR ADJACENT TO THIS HEATER OR ANY OTHER APPLIANCE. THIS APPLIANCE SHALL NOT BE INSTALLED IN ANY OTHER LOCATION WHERE FLAMMABLE LIQUIDS OR VAPORS ARE LIKELY TO BE PRESENT. WARNING! THIS APPLIANCE IS UNSUITABLE FOR USE AS A POOL HEATER.

THIS APPLIANCE IS NOT INTENDED FOR USE BY YOUNG CHILDREN OR INFIRM PERSONS WITHOUT SUPERVISION. YOUNG CHILDREN SHOULD BE SUPERVISED TO ENSURE THAT THEY DO NOT PLAY WITH THE APPLIANCE.

INSTALLER: AFFIX THESE INSTRUCTIONS TO OR ADJACENT TO THE WATER HEATER.

OWNER: RETAIN THESE INSTRUCTIONS AND WARRANTY FOR FUTURE REFERENCE.

ALL TECHNICAL AND WARRANTY QUESTIONS SHOULD BE DIRECTED TO THE COMPANY LISTED ON THE WARRANTY, OR RATING PLATE WHICH CAME WITH YOUR HOT WATER HEATER.

**Appliance repair is not a do it yourself type of repair.
All repairs should be performed by a qualified service agency.**

SPECIFICATIONS AND DATA FOR SUBURBAN STORAGE HOT WATER HEATER

- Specifications:**
Capacity: 17.7 Liters (SW5EA) 26.4 Liters (SW7EA)
Maximum Working Pressure: 850 kPa
Electrical:
Heating Element 240 Volts 50 HZ A.C. 1440 Watts 6 Amp
- Width:** 320mm
Height: 320mm
Depth: 450mm (SW5EA) 500mm (SW7EA)
- Location of hot water inlet is 70mm from top dead center.
Location of cold water inlet is 55mm from bottom dead center.
- DO NOT** place articles on or against this appliance.
DO NOT use or store flammable materials near this appliance.

INSTALLATION REQUIREMENTS

WARNING! Installation of this appliance must be made in accordance with the written instructions provided in this manual. No agent, representative or employee of Suburban or other person has the authority to change, modify or waive any provision of the instructions contained in this manual.

NOTE: Do not install the water heater with the door facing toward the forward end of the coach. See Figures 9, 10 and 11.

This appliance shall be installed only by authorised persons and in accordance with the manufacturer's installation instructions, electrical wiring regulations, local water supply regulations, and any other statutory regulations. Installation shall be in accordance with AS/NZS 3500.4.

- Discharge pipe must be mounted at the pressure relief valve and installed through floor line of caravan or motor home, and must be left open to free air so as water can escape if required and is to be installed in a continuously downward direction and in a frost-free environment. For convenience, a break -thru grommet has been provided in the bottom of the control housing. The center of the grommet may be pierced and piping routed through.
- A mains pressure reducing valve must be installed in the incoming water line with a rating of 350 kPa (50 psi). **Please Note:** Warranty will be void if pressure reducing valve is not installed.

INSTALLATION INSTRUCTIONS

Keep the heater at least 25mm clear of anything that is combustible, like walls, cupboards and timber.

Provide an opening flush with floor in outer wall of coach as shown. Wall of coach should be framed as shown in Figure 1. Maintain inside dimensions listed below. Do not install on carpet unless the carpet is covered by a metal shield at least 50mm greater than the width of the water heater.

INSTALLATION USING HINGED DOOR

(See Figure 2 for illustration)

- In some limited accessibility applications, the chocks as illustrated in Figure 3 must be installed prior to setting water heater into position. Install chocks, one on each side of water heater, as illustrated in Figure 3.
- Position heater into framed opening as illustrated.
- On mesa or yoder type sidewalls, flatten the wall area around the opening.
- Caulk around framed opening (trailer skin) as illustrated.
- Lay a bead of silicone caulking (or suitable caulking) around the inner edge of the control housing (top, bottom and sides). See detail "A" in illustration. This will seal frame to control housing.
- Apply a bead of silicone caulking (or suitable caulking) around back side of door frame. See detail "A" in illustration. This will seal frame to coach skin.
- Fit the door frame into control housing (over the caulking already applied) and pull frame tight to control housing using the three (3) No. 8-15 x 3 1/2" screws provided.
- Push water heater into framed opening until back side of door frame (now attached to control housing) is against the side of the coach and firmly attach with screws around the perimeter of the frame. **NOTE:** The two (2) holes in bottom of frame identified as "A" in Figure 2 are also used to mount door hinge to the frame.
- If already installed, confirm chocks are supporting the water heater correctly. If not already completed, install chocks, one on each side of water heater as illustrated in Figure 3.
- Attach door to frame as illustrated.
- Close the door so that the door latch protrudes through the slot in the door. Turn latch 90 degrees to fasten door.

MAKING WATER CONNECTIONS

WARNING! A tempering valve or other similar device must be installed between the outlet of the hot water service and any faucet.

Connect water lines to rear of unit. Suitable fittings must be used in rear of hot and cold water connections. **DO NOT** glue metal fittings. This will void warranty.

NOTE: Inside each fitting is a plastic fill tube installed by manufacturer. Its purpose is to enhance water circulation. **DO NOT REMOVE THE PLASTIC FILL TUBES.**

Fill tank with water. Always open both the cold and hot water taps when filling vehicle water tank to allow air pockets to be forced out of the water heater. When tank is filled, turn off taps and check for leaks at connections.

After leak testing, drain water from tank.

MAKING ELECTRICAL CONNECTIONS 240 VOLTS A.C.

- Refer to Figure 2 for location of A.C. junction box.
- The electrical connection must be made to conform with the local authority having jurisdiction or in the absence of such requirement with the latest Australian electrical code. All electrical work to be conducted by a licensed electrician.
- Check rating plate and wiring diagram (Figure 5) before proceeding. Install a fused safety switch or circuit breaker of adequate capacity between heater and electrical power source. Attach the active and neutral wires from the fused switch or breaker to corresponding terminals in heater junction box. An earth wire from a well grounded source must be attached to the earth terminal in the junction box.

CAUTION: Before applying the 240 VAC power to the water heater junction box, be sure the switch for electric element is in the "OFF" position.

WARNING! Before the switch for the electric element is turned to the "ON" position, the water heater tank must be filled with water. See "SAFETY WARNINGS"

MAINTENANCE

WARNING! If the user of this appliance fails to maintain it in the condition in which it was shipped from the factory or if the appliance is not used solely for its intended purpose or if appliance is not maintained in accordance with the instructions in this manual, then the risk of a fire exists which can cause personal injury, property damage or loss of life.

WARNING: For your safety, all repairs should be performed by an authorised service person.

- Periodically check wiring and wire connection to be sure wiring is not damaged/frayed and that all terminals and connections are tight and in compliance with codes (See "Making Wire Connections").

- B. The following is information regarding Hot Water Services and corrosion of the tank in Australia. The single biggest factor is metal/water contact.
1. Mains Water Connection- For correct performance and warranty of the unit, when connected to mains water supply, pressure must be limited to approximately 350 KPA (50 PSI) by the use of a suitable pressure regulator. Failure to do so will void warranty.
 2. A Suitable 1/2" BSPT fitting must be used for coupling HWS to water supply.
 3. Water supply is an overall factor.
 4. Tanks should be drained and flushed regularly - how often depends on soluble/silt content in water. Outback areas will be more of a problem than major city supplies.
 5. Do not use bore water. This will void your warranty as the salt contents of bore water are extremely high.
 6. The life of the anodes, which are a low valve replacement part, varies with water quality. Anodes must be inspected periodically. Use only genuine Suburban anode rods. Use of other anodes may void the warranty. Please see Anode Protection Section.
 7. Your water system should be operated periodically even though the van is not being used, at least twice per week.
 8. Anodes must be checked every 6 (six) months. Please see Anode Protection Section.

SAFETY WARNINGS

WARNING! It is imperative that the water heater tank be filled with water before operating the water heater. Operation of the water heater without water in the tank may result in damage to the tank and/or controls. This type of damage is not covered by the limited warranty.

WARNING! Hydrogen gas may result if you have not used this heater for two weeks or more. **HYDROGEN GAS IS EXTREMELY FLAMMABLE.** To reduce the risk of injury under these conditions, open the hot water faucet for several minutes at the kitchen sink before you use any electrical appliance connected to the hot water system. If hydrogen is present, you probably will hear an unusual sound such as air escaping through the pipe as the water begins to flow.

Hydrogen gas may be present even after water has been drained from the tank. Open faucet at sink and allow system to vent for several minutes (5-10 minutes).

Do not smoke or have any open flame near the open faucet.

Should overheating occur, shut off the electrical supply.

Do not use this appliance if any part has been submerged under water. Immediately call an authorised service technician to inspect the appliance and to replace any part of the control system that has been submerged under water.

Do not alter the operation of your water heater nor change the design/construction of your water heater. Accessories are being marketed for RV products which we do not recommend. For your safety, only factory authorized parts are to be used on your water heater

Pressure relief valve to be operated at least once every 6 months to remove lime deposits and verify it is not blocked. Failure to do so may result in heater exploding. Continuous leakage from valve may indicate a problem with unit.

NOTE: Always open both the cold and hot water faucets when filling vehicle water tank to allow air pockets to be forced out of the water heater. When water flows from the heater faucets, close both faucets.

WARNING! Do not store or use combustible materials or liquids near or adjacent to this heater. The appliance shall not be installed in any location where flammable liquids or vapors are likely to be present.

Be sure the power is "OFF" to the water heater during any type of refueling and while vehicle is in motion or being towed.

WARNING! The thermostat on your water heater is not adjustable. It is a temperature sensing limit designed to maintain a temperature of 60°C to comply with AS/NZS 3500 Part 4.2. Water temperatures over 60°C can cause severe burns instantly or death from scalds; therefore, be careful when using hot water. Children, disabled and elderly are at highest risk of being scalded. Always feel water before bathing or showering. Children or infirm persons must not adjust or operate any electrical controls on this unit.

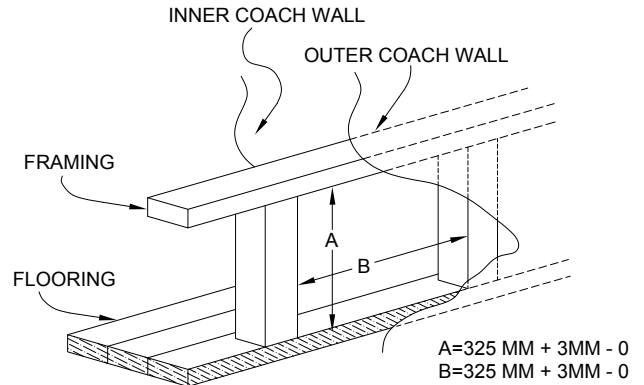

Figure 1

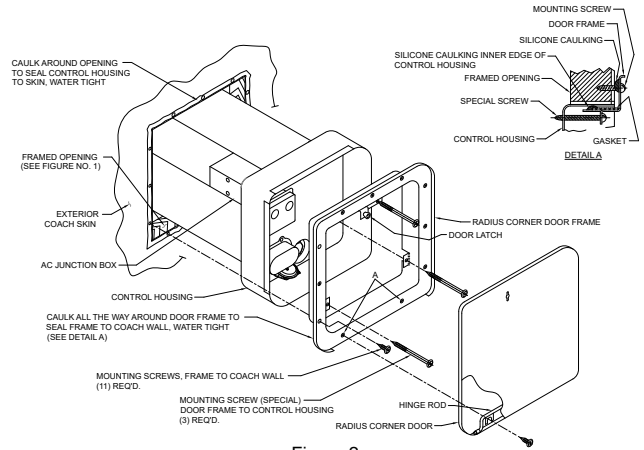

Figure 2

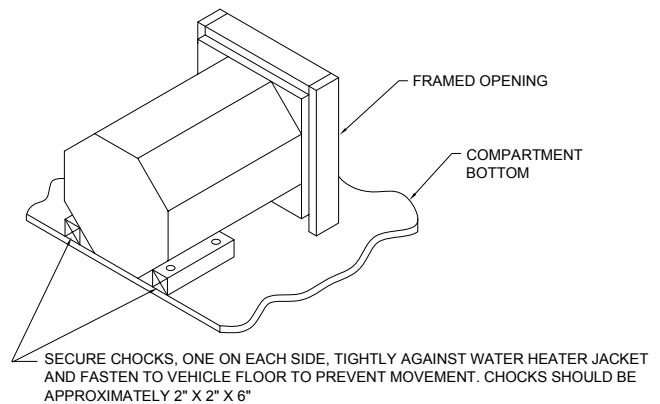

Figure 3

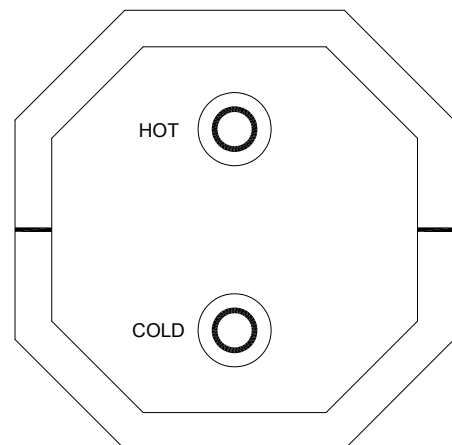

Figure 4

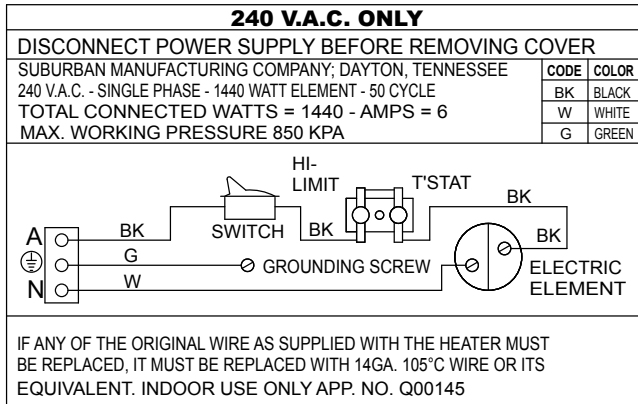

Figure 5

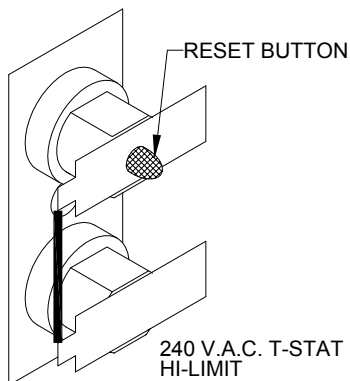

Figure 6

THERMOSTAT AND MANUAL RESET

The model water heaters listed above are equipped with a high temperature limit as a cut-off device. Temperature above 82°C will cause manual reset button to shut down the electric element.

To activate element, the water temperature must be below 37°C. Push reset button to

ANODE PROTECTION

The tank in this water heater is protected by a magnesium or aluminum anode to prolong the life of the tank. Removal of the anode will decrease tank life and will void the warranty on the inner tank. Anode must be checked every 6 (six) months, and replaced if below 50% of original diameter, failure to do so will void your warranty. Use only genuine Suburban anode rods. Use of other anodes may void the warranty. Anode performance depends on water quality, therefore are **NOT** covered by warranty.

To prevent a water leak when replacing the anode rod, a pipe thread sealant approved for potable water (such as Teflon Tape) must be applied to the threads of the anode rod. Proper application of a thread sealant will not interfere with the anode's tank protection.

Anode Dimensions: Length - 215mm, Diameter - 17mm.

NOTE: Tank is drained by removing anode rod (See "Drain and Storage" instructions).

To extend anode life, drain water from tank whenever RV is not being used. Avoid any extended time of non-use with water in tank. Also, refer to the section on winterizing.

WARNING! Do not replace the anode rod with any non-Suburban accessory part, such as an "add-on" electric heating element. Items such as these are not approved to be installed in Suburban products. They could create an unsafe condition and will also void all warranties.

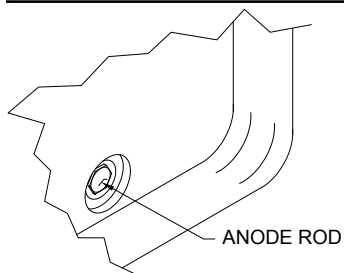

Figure 7

PRESSURE RELIEF VALVE

The temperature and pressure relief valve is designed to open if the temperature of the water within the heater reaches 98.9 degrees Celsius, or if the water pressure in the heater reaches 850 kPa. Recreational vehicle water systems are closed systems and during the water heating cycle the pressure build-up in the water system will reach 850 kPa. When this pressure is reached, the pressure relief valve will open and water will drip from the valve. This dripping will continue until the pressure is reduced to below 850 kPa. Once the pressure has dropped below 850 kPa, the valve will close. This condition is normal and does not indicate a defective relief valve.

WARNING! Do not plug, cap or reduce the outlet pressure and temperature valve.

The pressure-relief device is to be operated regularly to remove lime deposits and to verify that it is not blocked.

DANGER! Failure to operate the relief valve easing gear at least once every six months may result in the water heater exploding. Continuous leakage of water from the valve may indicate a problem with the water heater.

WATER WEEPING OR DRIPPING FROM PRESSURE RELIEF VALVE

You may experience water weeping or dripping from your water heater's Pressure and Temperature (P & T) Relief Valve when your water heater is operating. Water weeping or dripping from the P & T Valve does not always mean the P & T Valve is defective. As water is heated, it expands. The water system in a recreational vehicle is a closed system and does not allow for the expansion of heated water. When the pressure of the water system exceeds the relieving point of the P & T Valve, the valve will relieve the excess pressure. Suburban recommends that a check valve not be installed directly at the inlet to the water heater tank. This will increase weeping of the pressure relief valve.

One way to reduce the frequency of this occurrence is to maintain an air pocket at the top of the water heater tank. This air pocket will form in the tank by design. However, it will be reduced over time by the everyday use of your water heater.

To replenish this air pocket:

1. Turn off water heater.
2. Turn off cold water supply line.
3. Open a tap in the RV.
4. Pull out on the handle of the Pressure Relief (P & T) Valve and allow water to flow from the valve until it stops.
5. Release handle on P & T Valve - it should snap closed.
6. Close tap and turn on cold water supply; as the tank fills, the air pocket will develop.

Repeat this procedure as often as needed to reduce the frequency of the weeping of the P & T Valve. If the weeping persists after following this procedure, you may elect to install an expansion or accumulator tank in the cold water line to relieve the pressure caused by thermal expansion.

Suitable fittings are required to be installed in the pressure relief valve for piping water away. A hole for the discharge pipe must be drilled in the bottom of the control housing and the piping passed through the hole. The hole through which the piping passes must be sealed water tight.

The discharge pipe must not be reduced in size along its length. The length and number of bends should be kept to a minimum and should be supported in a manner to reduce the risk of crushing or blockage.

Please contact your local dealer for assistance.

DRAINING AND STORAGE INSTRUCTIONS

If unit is to be stored during the winter months, the heater must be drained to prevent damage in the case of freezing temperatures.

1. Turn off electrical supply to the water heater.
2. Turn off pressure pump on the water system.
3. Open both hot and cold water taps.
4. Open the drain on the water heater. (Remove anode rod)
5. Follow RV manufacturer's instructions for draining of the entire water system.

NOTE: Be certain to refill water heater with water before using the appliance.

ODOR FROM HOT WATER SYSTEM

Odor from the hot water system is not a service problem and many water supplies contain sufficient amounts of sulphur to produce an odor. The odor is similar to rotten eggs and is often referred to as "sulphur water". It is not harmful - only unpleasant to smell. Sulphur water can be caused by a chemical action or by bacteria. The solution to eliminate is chlorination of the water system. Add about six (6) ounces of chlorinated common household liquid bleach to each 10 gallons in the water tank. Then run the chlorinated water throughout the system, opening each faucet one at a time until you smell the chlorine. Let the RV sit for a few days and the chlorine should take care of the problem. Then you will need to take care of the chlorine. Remove the chlorine by flushing the system with fresh water. This may take several attempts. You may consider adding a filtering system that removes chlorine and prevents sulphur water. If the sulphur or rotten egg smell continues, flush the system once again as described above and replace anode rod as necessary.

REMOVING WATER HEATER

1. Shut off unit and disconnect power supply from water heater.
2. Shut off water supply. Drain water from tank following instructions under "Draining and Storage".
3. Disconnect hot and cold water lines from water heater.
4. Remove screws or nails securing control housing to framed opening.
5. Slide heater out. To reinstall, follow instructions in manual under "Installation Instructions".

WINTERIZING

If your water heater plumbing system is equipped with a bypass kit, use it to close off the water heater, drain the water heater completely and leave the water heater closed off (out of the system) in the bypass position *particularly* if you are introducing antifreeze into the plumbing system. Antifreeze can be very corrosive to the anode rod creating premature failure and heavy sediment in the tank. If the plumbing system is not equipped with a bypass kit, and you intend to winterize by adding antifreeze to the system, remove the anode rod (storing it for the winter) and replace it with a 19mm drain plug.

FOR YOUR SAFETY READ BEFORE OPERATING

WARNING! If the user of this appliance fails to maintain it in the condition in which it was shipped from the factory or if the appliance is not used solely for its intended purpose or if appliance is not maintained in accordance with the instructions in this manual, then the risk of a fire and/or the production of carbon monoxide exists which can cause personal injury, property damage or loss of life.

OPERATING INSTRUCTIONS

WARNING! If you do not follow these instructions exactly, a fire or explosion may result causing property damage, personal injury or loss of life.

WARNING: Before operating water heater, be sure tank is filled with water. See "Safety Warnings".

Do not use this appliance if any part has been under water. Immediately call an authorised service technician to inspect the appliance and to replace any part which has been under water.

Electric water heaters are designed to operate with a minimum amount of service problems; however, proper operation and care is essential.

By far the most common trouble with electric water heaters results from energizing the water heater before it is filled with water. Even brief operation of the electric element without water in the tank will burn-out the electric heating element.

1. STOP! Read the safety information provided.
2. To energize the electric heating element, turn the switch to "ON"

Reverse the procedure to disconnect electric heating element.

The switch is located behind the water heater door in the lower left corner of the control housing. The water temperature will be regulated by the thermostat.

This procedure is necessary so as to prevent 240 V element from operating.

TO TURN OFF WATER HEATER

1. Turn switch to "OFF" position.
2. Turn off electrical power to the appliance.
3. If vehicle is to be stored or heater is going to be turned off while subject to freezing temperature, drain water heater. (See "Draining and Storage Instructions.")

TROUBLE SHOOTING GUIDE

This can be used as a guide that will enable you to solve most of the problems that the customer could have with the heater.

Will Not Come On	Not Enough Hot Water	Water Too Hot	Possible Cause
XXXXX			Switch not "ON" (See operating instructions)
XXXXX			Electrical Supply Interruption
	XXXXX		Check thermostat position. Be sure it is properly mounted.
		XXXXX	Check thermostat position. Be sure it is properly mounted.

IF AFTER CHECKING THE CHART AND THE UNIT WILL STILL NOT PERFORM - TURN THE APPLIANCE OFF AND CONTACT THE AUTHORISED SERVICE PROVIDER.

PARTS ILLUSTRATION AND REPLACEMENT PARTS LIST

PARTS LIST FOR MODELS: SW5EA • SW7EA

Only factory authorized parts are to be used. Do not attempt to repair defective parts.

When ordering repair parts from your dealer or a distributor, always give the following information:

1. Part Number (Not Item No.)
2. Part Description
3. Model No. and Serial No. of your Heater
4. Number of Parts Required

ITEM NO.	DESCRIPTION	PART NUMBER
1	Valve, Pressure Relief	161166
2	Cover, Thermostat/Hi-Limit	090562
3	Gasket, Thermostat Cover	070987
5	Grommet	070874
8	Electric Element with Gasket	520831
9	Anode	232767
10	Bushing, Snap 1/2"	070270
11	Switch, Electric Element with pin	232668
12	Gasket, Switch	071016
14	Switch Assembly, 220 V.A.C. T-Stat/Hi Limit	232317
15	Cover, Junction Box	090576
16	Bushing, Snap 7/8"	230218
17	A.C. Junction Box Assembly	090575
18	Nut, 10-24 Keps (Green)	121576
19	Bushing, Snap 7/8"	230218
20	Foam Jacket (2 Required) SW5EA	520867
	Foam Jacket (2 Required) SW7EA	520868
21	Gasket, Element Cover	070988
22	Cover, Element	090445
23	Terminal Block	232669
24	Door, Radius Corner - PW (Not Shown)	6268APW Polar White
25	Plug, Break Through	233309

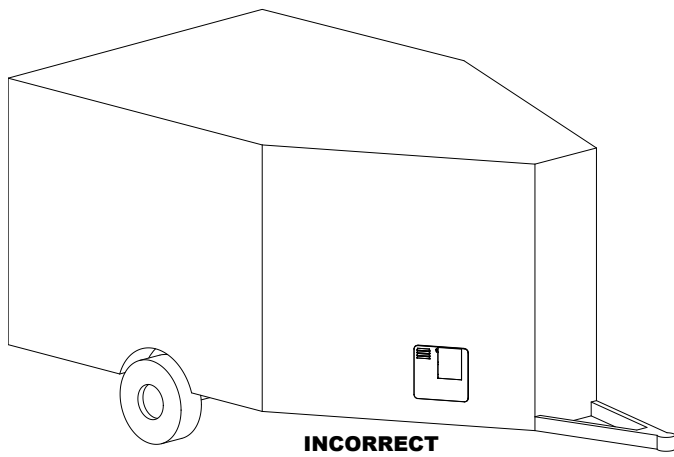
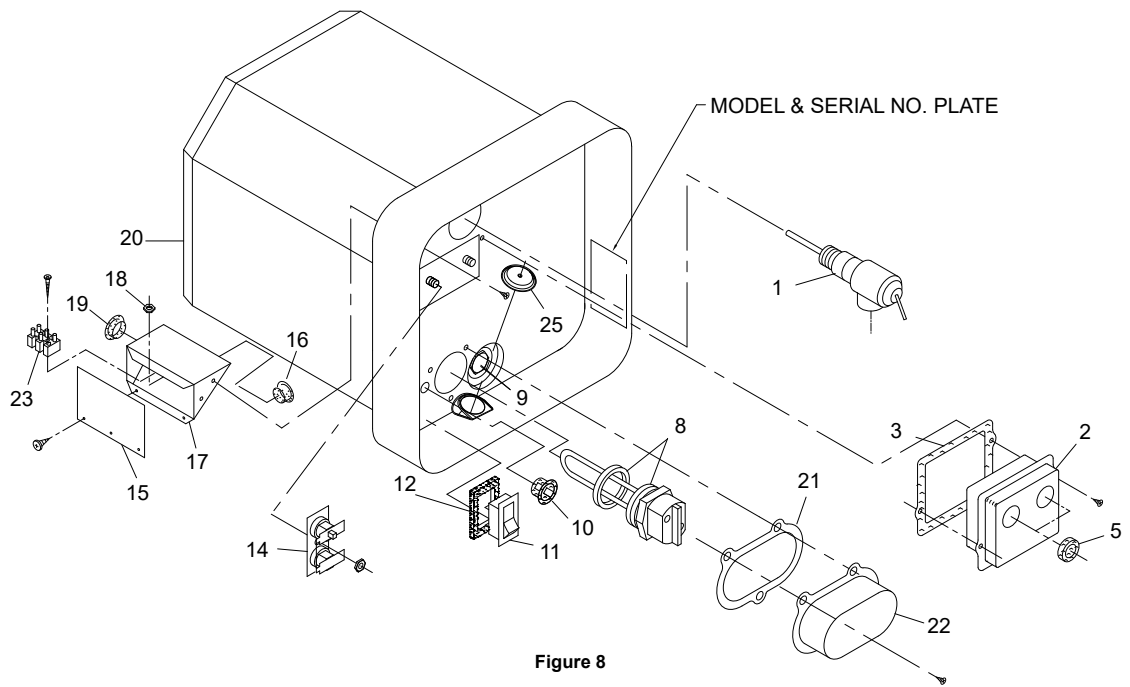

Figure 9

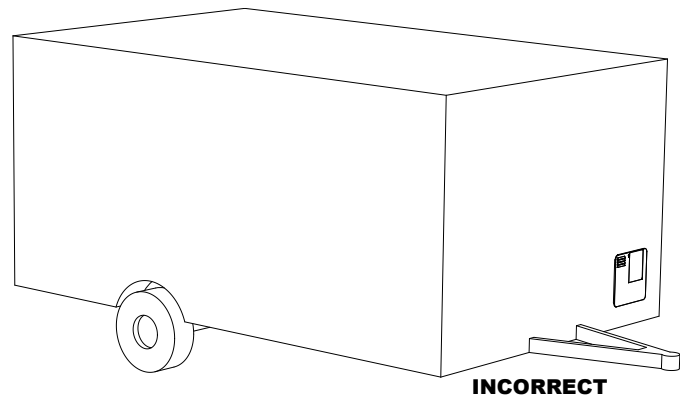

Figure 10

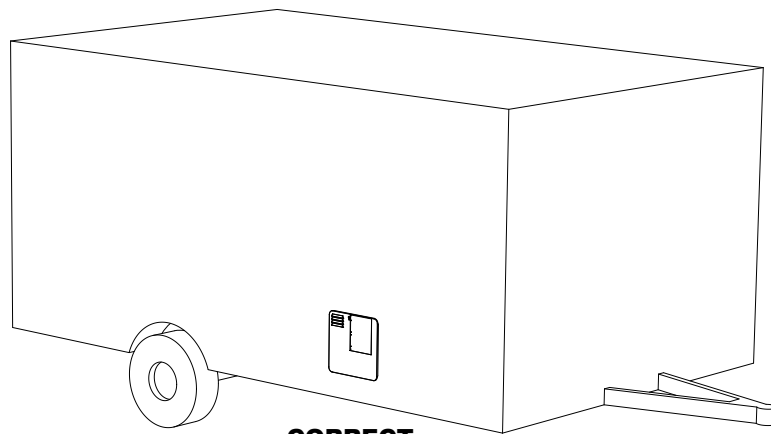

Figure 11

RECREATIONAL VEHICLE WATER HEATER LIMITED WARRANTY

THIS IS A LIMITED 24 MONTH WARRANTY ONLY!!

This water heating product is warranted by Coast to Coast RV Services to the original purchaser to be free from defects in material and workmanship under normal use and maintenance for a period of 24 months from the date of purchase, regardless of the commencement date of use. It is the responsibility of the consumer/owner to establish the warranty period. Coast to Coast RV Services does not use warranty registration cards for its standard warranty. You are required to furnish proof of purchase date through a bill of sale or other payment record.

Coast to Coast RV Services will replace any parts that are found to be defective within the first 24 months and will pay a warranty service allowance directly to the authorized Coast to Coast RV Services approved Agent at rates mutually agreed upon between Coast to Coast RV Services and its authorized service center or agent. Water heater must be returned to a Coast to Coast RV Services authorized service center. Coast to Coast RV Services will not bear costs involving traveling time from their service agents.

Service agents can perform warranty repairs on site but all traveling time will be paid by owner of Vehicle or Caravan.

COAST TO COAST RV SERVICES WILL NOT BE RESPONSIBLE FOR:

1. Normal maintenance as outlined in the installation and operation instructions owner's manual including cleaning of the component parts and cleaning or replacement of the burner orifice. Any water damage arising directly or indirectly from any defect in the water heater or component parts or from its use.
2. Initial check outs and subsequent check outs which indicates the water heater is operating properly or diagnosis without repair.
3. Damage or repairs required as a consequence of faulty or incorrect installation or application not in conformance with installation instructions.
4. Failure to start or operate due to loose or disconnected wire, water or dirt in controls, fuel lines and gas tanks, improper gas pressure or low voltage.
5. Cleaning adjustment of components, electrode, burner tube, pilot and thermocouple.
6. Costs incurred in gaining access to the water heater.
7. Parts or accessories not supplied by Coast to Coast RV Services.
8. Freight charges incurred from parts replacement.
9. Damage or repairs as a consequence of any misapplication, abuse, unreasonable use, unauthorized alteration, improper service, improper operation or failure to provide reasonable and necessary maintenance.
10. Any products whose serial number has been altered, defaced or removed.
11. Damage as a result of floods, winds, lightning, accidents, corrosive atmosphere or other conditions beyond the control of Coast to Coast RV Services.
12. Any special indirect or consequential property, economic or commercial damage of any nature whatsoever.

Some states do not allow the exclusion of accidental or consequential damages, so the above limitation may not apply to you.

NO REPRESENTATIVE, DEALER OR OTHER PERSON IS AUTHORIZED TO ASSUME FOR COAST TO COAST RV SERVICES ANY ADDITIONAL, DIFFERENT OR OTHER LIABILITY IN CONNECTION WITH THE SALE OF THIS WATER HEATING PRODUCT.

For full warranty terms and conditions, please visit www.coastrv.com.au or www.coastrv.co.nz

This warranty gives you specific legal rights. You may also have additional rights which vary from state to state.

IF YOU HAVE A PRODUCT PROBLEM

First:

If your RV has its original water heater and is still under the RV manufacturer's warranty. Follow the steps described in the RV owner's manual.

Second:

Contact: Coast to Coast RV Services
PO Box 6287
Silverwater NSW 1811 Australia
Phone: (02) 9645 7600
Fax: (02) 9645 7688
Email: warranty@coastrv.com.au